

1. For each of the following list all the possible gametes that the individual can produce.

- a) Yy pea plant
- b) tt (short) pea plant
- c) Woman heterozygous for the BRCA1 gene (BRCA1 brca1)
- d) Pp Yy dihybrid pea plant
- e) pp yy tester strain
- f) Yy tt pea plant

2. In pea plant Tall (T) is dominant to short (t) and yellow peas (Y) are dominant to green (y). Fill out the Punnett square below for a dihybrid cross for these traits. Include gametes, genotypes, and phenotypes.

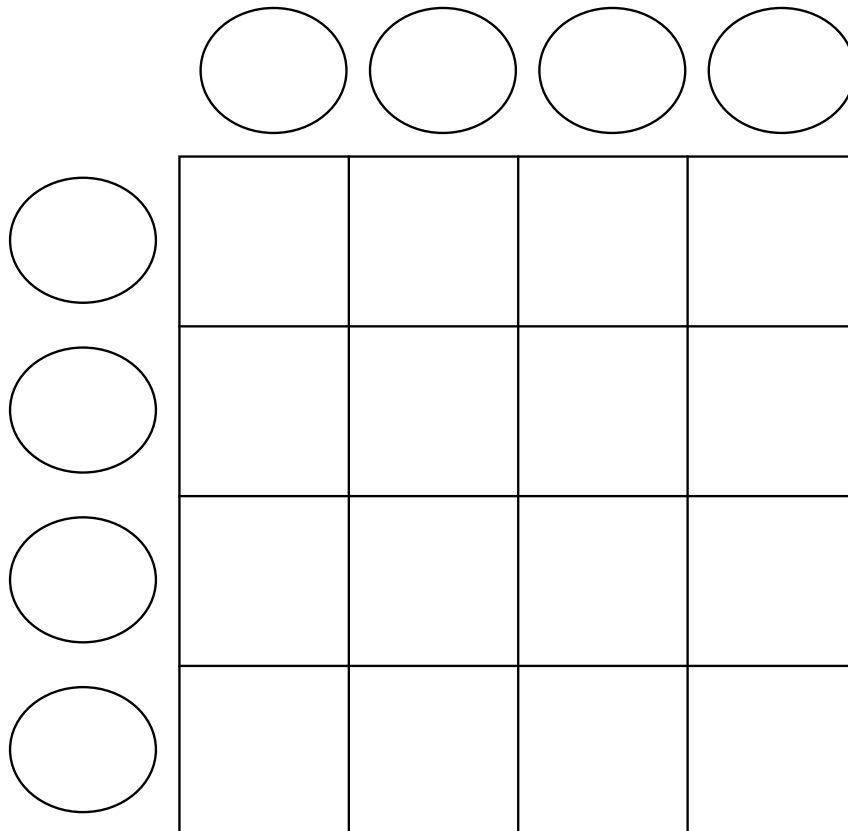

3. a) What is the likely mode of inheritance of this trait?  
b) Number the individuals according to the standard method.

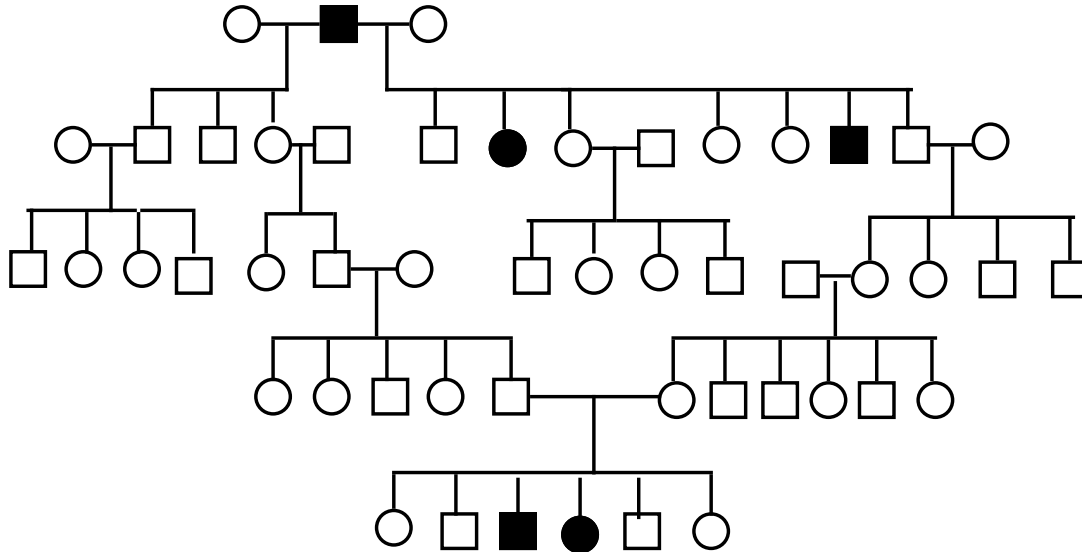

4. The ability of the human digestive system to break down the red color in beets is an autosomal dominant phenotype. The inability is recessive and is detected by red coloration of the urine after eating beets (we call this phenotype "secretor"). A non-secretor woman with a secretor father marries a nonsecretor man who had a secretor daughter in a previous marriage.

- a) draw the pedigree of these individuals  
b) what is the probability that their first child will be a secretor boy?  
c) what is the probability that their first two children will be secretors?

5. Four babies were born in a hospital on a night in which an electrical blackout occurred. In the confusion name bracelets were not put on the babies. The blood types of the four babies were 1) O, 2) AB, 3) A, and 4) B. The blood types of the four anxious parents were i) O and O, ii) AB and O, iii) A and B, iv) B and B. You are called in as a genetic advisor.

a) What are the possible genotypes for people of each bloodtype ?

O \_\_\_\_\_ AB \_\_\_\_\_ A \_\_\_\_\_ B \_\_\_\_\_

b) What is your analysis in regards to which child belongs to which couple?

6. A normal couple has three children. The youngest child has cystic fibrosis (as is always the case, unless you are told otherwise, assume the other children are phenotypically normal). Show your work!

a) What is the likelihood that both of the other children are carriers?

b) What is the likelihood that neither of the other children are carriers?

c) What is the likelihood that one is a carrier and one isn't?

d) What is the likelihood that the oldest one is a carrier and the second child is not?

e) What is the likelihood that if they have a fourth child, that it will be a carrier?